

Equipment Specifications: General Duty

Bulk Case Loading

Controls: (1) Main cabinet with Allen-Bradley MicroLogix PLC, Allen-Bradley Power Flex 4 variable speed drive, (1) Automation Direct C-More 6" color HMI, main disconnect, emergency stop buttons, photo sensors, etc.

Electrics: 110 VAC, single phase, 60Hz, Nema 12

Construction: Heavy-duty, painted steel with adjustable (+/- 2") casters

Motor/Reducer: World Wide Electric AC motor with attached World Wide Electric gear reducer

Pneumatics: Valve by SMC, Cylinders by SMC

Air: 80 PSI

Rate: Up to 60 bags per minute

Belt Speed: Variable up to 80 FPM

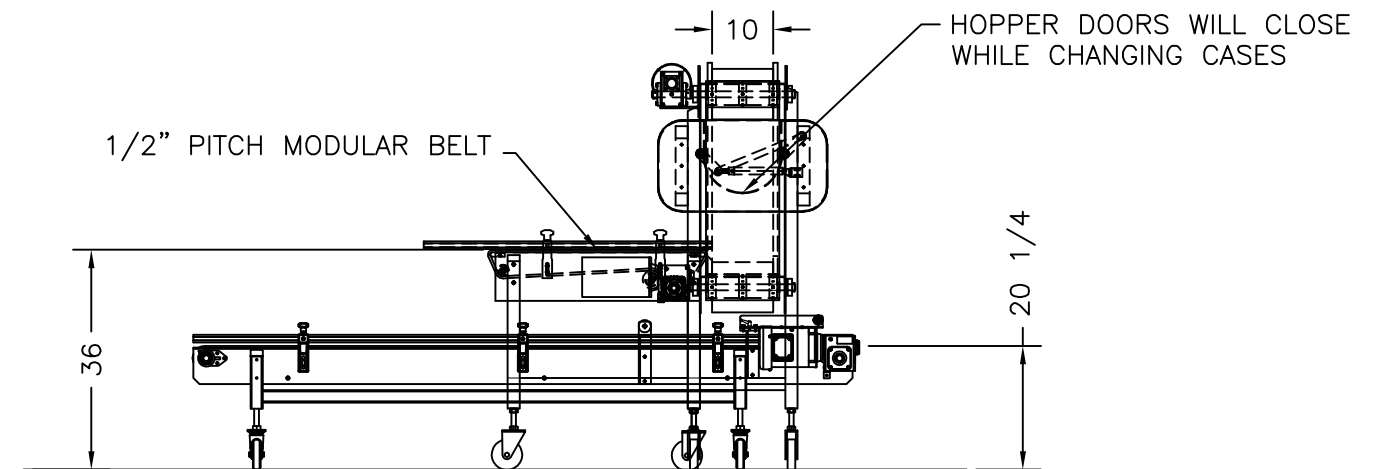
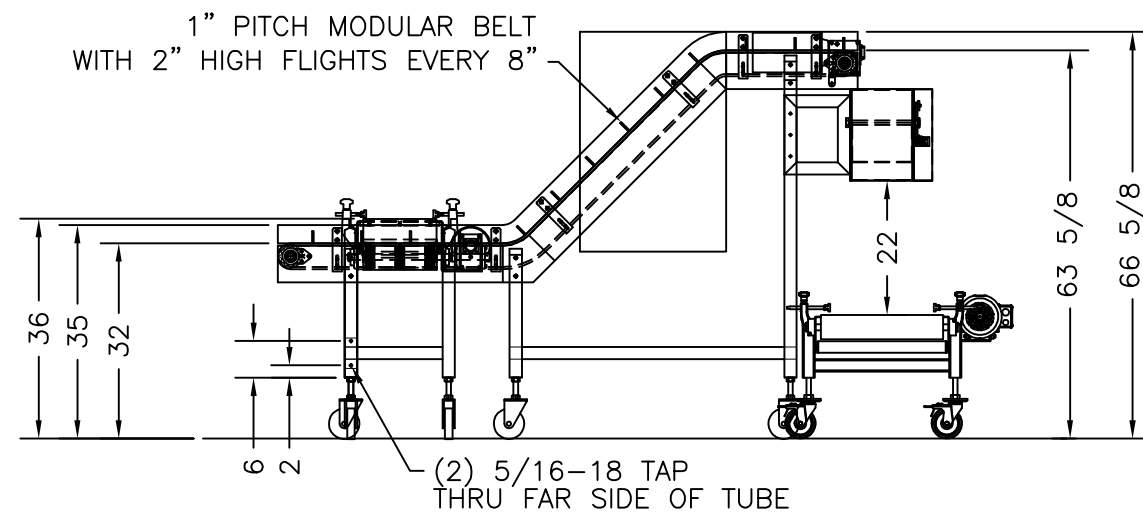

Approved: _____

Date: _____

		<small>CONFIDENTIAL</small> <small>THESE DRAWINGS AND SPECIFICATIONS CONTAIN PROPRIETARY AND CONFIDENTIAL INFORMATION OF WRABACON INC. AND MAY NOT BE COPIED OR OTHERWISE REPRODUCED, TRANSFERRED, SOLD, PUBLISHED, OR DISCLOSED WITHOUT PRIOR WRITTEN PERMISSION OF WRABACON INC.</small>			SCALE 1:32	JOB NO. 6516
		SHEET 1 OF 1				
DRAWN BY EJC	DATE 2/13	TITLE CASE LOADING SYSTEM				
CHECKED BY	DATE					
AS SHIPPED	DATE	DRAWING NO. 6516-00-000r2	SIZE B			